

Advisory Neighborhood Commission 6D
Minutes of Business Meeting – November 14, 2016
Held at 200 I St. SE, Washington DC 20024

Andy Litsky, Chair

As approved at the December 12th, 2016 Public Business meeting
Correspondence sent after the November 14th, 2016 Public Business meeting is also attached.

The Commission convened at 7:00 p.m. The following commissioners were in attendance at the beginning of the meeting: Roger Moffatt, Stacy Cloyd, Meredith Fascett, Marjorie Lightman, and Andy Litsky (chairing).

Approval of Agenda

CM Fascett moved to approve the agenda, and CM Litsky seconded. With the addition of a motion about the intersection of 4th and M SE, one about the health clinic on Delaware Ave. SW, and one about the intersection of 4th and M SW, the agenda was approved 5-0-0.

Introduction of Commissioners

Meeting Announcements

- The next meeting is Monday, December 12 at 1100 4th St. SW, 2nd floor.
- CM Fascett: Square 767 DCHA meeting tomorrow 6pm at Navy Yard Community Center
- CM Fascett: ANC passed a resolution about paid leave last month, and there will be a Council hearing on the bill 12/6
- CM Moffatt: PSA 105 meeting on 11/16 at 7pm at the SW library
- CM Litsky: council hearing 11/16 on campaign finance bill—call 727-8275 for details
- CM Litsky: The SW Neighborhood Plan won an award from the American Planning Association and the Office of Planning’s celebrating 6pm tomorrow at Atlas Theater.
- CM Litsky: DC Public Library put out an RFP for the SW library so the redesign is really happening!
- Bill Schickler: Next Wednesday Tommy Wells is the guest at the SW AARP meeting—11am at River Park
- Georgine Wallace: 12/10 is the next library book sale. 11/30 meeting about redesign of SW and MLK libraries at 7pm. On 12/17 from 3-4:30, Santa’s secret book shop: area kids can choose books to give as gifts and wrap them there.

Public Safety Report

Lt. Williams said lots of people, especially single white females, are being assaulted and having their belongings, especially cell phones, being stolen. Folks are targeting Uber drivers and their passengers—stay inside and wait for your Uber. Robberies are a problem but MPD is making a lot of good, quick arrests. One big problem is that juveniles and other offenders are released back to the street very quickly—MPD can arrest the same person over and over if prosecutors don’t hold them.

In PSA 105, crime has gone down a lot. Many fewer robberies with weapons. 56% drop in violent crimes and property crimes are down 27%. In PSA 106, a 25% increase in robberies and 77% increase in property crimes.

CM Hamilton commended MPD for the haunted house at 1D HQ.

Approval of Prior Month's Minutes

CM Cloyd moved to approve the October minutes and CM Lightman seconded. The minutes were approved 6-0-0 (CM Hamilton arrived).

Other Presentations and Resolutions

New Farmer's market in SE—Nony Dutton of Freshfarm requested a letter of support for a Sunday market on the southern block of Canal Park from 10am-2pm from May to September 2017. The BID and Canal Park support it. The market will accept SNAP, WIC, and Senior Food Program and double up to \$10 of those benefits each week. CM Cloyd asked that they not take producers away from SW Saturday market and their plan is to work with farms that don't already have a presence in Ward 6. CM Fascett asked if we could vote at our December meeting once we see the letters of support from the BID and adjacent businesses, who would be affected by the proposed closure of 2nd St SE. That worked with Mr. Dutton so the ANC took no action this meeting.

Update from DPR on Amidon sidewalk, Jefferson field, and SW Duck Pond—Peter Norden of DPR. Amidon sidewalk park has new lights. They are working on the timing to make sure they come on at dusk. They are looking for funding for additional projects and the SW BID has offered some maintenance support. At the Duck Pond, DGS has put out a request for some quotes for renovation, and once they get them they will engage the public to figure out priorities. At Jefferson field, 14 new trees will be planted there but they will not affect sports fields. They will mostly be on the north side of the field.

CM Lightman asked what duck pond items are getting quotes and was told: gazebo to replace playground (which doesn't meet safety standards), gateway to connect to parks to the east, improving the grounds with new trees and plants (in keeping with original landscape plans), replastering the pond, repointing brick, new trash cans.

CM Moffatt asked about the filtration system for the duck pond and Mr. Norden said that UV light and biofiltration are under consideration but not in this phase—they will be too expensive.

CM Fascett: what is the time frame by which DPR leadership makes its proposals for spending? That happened in September for FY18-22.

Bill Schickler: There are lawsuits in Virginia about turf fields. Is Randall's field dangerous? Mr. Norden said no—the problem there was crumb rubber, and Randall does not use crumb rubber.

Andrew Lightman: the permittees at Jefferson field drink and leave a lot of trash. What should we do? Mr. Norden said to call MPD. DGS and DPW are in charge of trash collection.

Will Rich: Is Verizon going to locate a cell tower at Randall? Mr. Norden says DGS is negotiating that, so there is cell coverage for inauguration. CM Cloyd noted BZA would have to approve it.

Cara Shockley: Did any West Nile cases come from the duck pond this year? Not that Mr. Norden heard. Chlorinating the water helped, but then no ducks came. Biofiltration will be a better solution.

11th St Bridge Park Update: Scott Kratz, who lives at 9th and I SE, is in charge of turning the old 11th St. Bridge into a park. Over 1000 public meetings have been held. Pre-construction will start next month. That means permitting, finalization of design, environmental assessment, etc. That will take about 18

months, and construction will take 18 months after that. There will be public art, engagement with the Navy Museum, and more. They are gardening at Virginia Ave. and 8th St. SE. They will be hosting the 3rd annual Anacostia River Festival on April 9 from 1-5pm in collaboration with the National Park Service and the Cherry Blossom Festival. They have an equitable development plan involving community land trusts, housing assistance clinics, and more—they are hiring a staffer to implement the equitable development plan. LISC has invested \$50 million to implement that plan. More information at bridgepark.org

Bill Schickler: how much public funding will you get? Mr. Kratz: \$11.45m from the District of the \$45 million total. Possibility that some of the rest will come from a federal TIGER grant if they win it. Foundations, private donors, and corporations will make up the rest.

Chris: how do people get access to the park? Mr. Kratz: on foot or bike via the riverwalk by the Navy Yard, the Anacostia river trail, the 11th Street bridge pedestrian path, and via bus because the 11th St. bridge has bus stops.

CBCC Update: Rikki Kramer said among the CBCC's goals are: quality education, neighborhood-oriented retail, community centers and recreation, and housing diversity. They can be the enforcement mechanism for community benefits agreements, in ways the ANC cannot. They refocused their efforts in several ways this year: a PUD task force (which involves creating generic asks of developers), a paid work experience plan for low-income residents, and discussion with landlords about commercial tenants, monitoring DC United community benefits agreement, and working with Friends of Randall and other groups. They submitted comments about the Buzzard Point Vision Framework. All of this is done based on community input. Gail Fast and Rhonda Hamilton will be on both the ANC and the CBCC board and the CBCC is also looking for more board members.

CM Lightman: The key is coordination with the ANC, but we are two different organizations. It's important that the distinction between the ANC and CBCC remain crystal clear. The research and data you provide is a vital contribution, as is the fact that you're able to enforce community benefits agreements.

CM Moffatt: can you brief the ANC quarterly? Ms. Kramer: yes, and we'll share our minutes.

CM Cloyd: please help me and Friends of Randall pressure DPR to offer programming at the site!

Resolution regarding 850 Delaware Ave. SW Health Clinic: CM Cloyd moved to send a letter to DOH, DGS, DHS, the Mayor, and Councilmember Allen asking for community involvement in any RFP for a health clinic operator and that the selection criteria includes continuity of care for Unity patients, connections to the community, experience serving people with public, private, and no insurance, and a variety of services. CM Hamilton seconded. Passed 6-0-0.

Alcoholic Beverages (ABC Committee Chair Coralie Farlee)

Dr. Farlee said that Bardo's contested fact-finding hearing is Wednesday 11/16.

Takorean: New Cooperative Agreement. Last month the ANC took no action on the license renewal, but the applicant agreed to negotiate a CA. They had not had a CA in the past. CM Litsky moved to send the CA to ABRA, CM Moffatt seconded. Passed 6-0-0.

Ziegfeld's/Secrets: The license (CN) is up for a renewal. The ABC committee noted that it had no ABRA incidents for at least 5 years and they follow their CA. So the committee recommends we send a letter in support of the renewal. CM Moffatt so moved, CM Litsky seconded. Passed 6-0-0.

The Bullpen I and II: This is really one site with two licenses. Eventually it will be built on, but they've applied for another renewal. The ABC committee recommends that we ask ABRA to provide extra supervision and rat control. CM Litsky so moved, CM Moffat seconded. Passed 6-0-0.

Penthouse CT renewal: 1212 4th St. SE. This is the bar on the roof of Vida. The ABC committee suggested the ANC take no action, given that ABRA reports that the last problem on the site was in 2006. CM Fascett noted that the establishment didn't exist in 2006 so it would be worth looking at the historic documentation [*note: after the meeting, Dr. Farlee checked with ABRA and was told that the 2006 incident happened at a similarly-named establishment with different ownership; the establishment in question for this CT renewal has never had an ABRA violation*]. She's gotten a few complaints, so she encouraged the ABC committee to visit the site and keep an eye on it for the future. The ANC took no action.

Development, Planning, and Transportation

Update on the Wharf: Matt Steenhoek: 332 days until Phase I's grand opening: 10/12/17. Z-dock is close to completion, and about 22 liveboards should move there around New Year's. Then their current docks will be removed and the recreation pier construction will start. The promenade near the park has opened. The rest of the park should be fully open by the Cherry Blossom festival with sections opening before that. Parcel 1 has started to go vertical. The phase 2 design team has been selected. Phase 2A includes an apartment, a condo, and an office building, among other things will require ANC approval soon—then Phase 2B is 2 more office parcels at some point in the future. Mid-2018 to Mid-2020 is the tentative construction time for Phase 2A. They are working on the NEPA process for Banneker Overlook. They are also working on a dock at East Potomac Park so a free jitney boat will take you from the recreation pier to East Potomac Park. It would run from March to December with room for 12 passengers and some bikes and golf clubs.

Maria Thompson: Parcels 2, 3, 4, and 5 have topped out. The interior construction should be less disruptive. They're working out issues with early construction and requests for after-hour permits. The ANC will get to vet requests for after-hours permits. Clark Construction has informed all its subcontractors about the new procedures. CM Carroll asked how Saturday work will balance with fish market traffic. Matt also noted that they're working with MPD, DDOT, DPW, the BID, and others about parking signage and enforcement by the fish market. CM Moffatt asked if Maine Avenue will stay closed after Phase I is opened and was told no, it will open up between Phase I and Phase II. CM Cloyd asked if after-hours permits will be needed for concrete pours this winter and was told there will be some need for that for Parcel 1, but it isn't a very big building. CM Lightman expressed concern about fish market parking and was told DDOT and DPW need to work on this. CM Fascett: are you having trouble getting concrete trucks to the site due to traffic? Ms. Thompson: Yes, starting at 5am worked pretty well. A few days they got a 4:30 am permit but that was only for just a few pours. Using the plant in Southwest worked better than using the one in VA because traffic from VA meant that the concrete was past its shelf life, especially when it was hot this summer and the shelf life is shorter. CM Litsky asked about the truck route and was told the drivers are all notified of it.

Elinor Bacon: the requirement is 35% CBE and they have 40%. They're required to have 51% of jobs going to DC residents and are currently at 49%. They knew it would grow over time because the earlier jobs involved highly technical underwater work and the current work has a broader pool of people who can do it. 26% of jobs went to ward 8 residents and that is above the goal of 20%. They're also beating their goals for apprenticeships of Ward 7 and 8 residents. They held a meeting targeted to certain divisions of construction so they can reach small CBE firms. Elinor is working with DOES on getting people for ongoing work at the Wharf—hotels, restaurants, landscaping, etc. They are working with Building Futures to target public housing residents in SW for pre-pre-apprenticeships on construction trades. 7 or 8 residents went through the program and are now in apprenticeships. They hired a property manager with experience running mixed-income housing. They are working with Cultural Tourism DC to do a mid-century modern heritage sign near Tiber Island. CM Lightman: please practice gender diversity in your hiring. Ms. Bacon: we're trying but it's not a requirement and so we don't track it. CM Carroll: Are you memorializing the solutions you're finding to First Source issues so that other developers can be successful on these issues? Ms. Bacon: we can talk with DSLBD about ways to do that. CM Fascett: will you have jobs for graduates of Building Futures? Ms. Bacon: yes, definitely. And DCHA has a pre-program for people who aren't ready for Building Futures. CM Fascett: it's hard to build community in mixed-income buildings so I want to hear about the operator's best practices. Cara Shockley: Thank you for what you're doing because 49% is a lot of local hiring. CM Carroll: yes, it is a good model for other developers that it can be done.

Bob Rubenkonig: December 3 is the 25th Annual Festival of Lighted Boats. 59 boats are registered. Next year the festival will move to its new site. Other events went well—movie nights, 196 people shredding paper last week, thousands of people at the Pumpkinpalooza, etc.

Rikki Kramer: when will the pedestrian path be open from Titanic to the fish market? 10/12/16.

CM Lightman: what is the steel frame in the park? A pergola.

CM Cloyd: when will the jitney open? As soon as the pier and the dock are open.

Community members: will there be kayak and stand-up paddleboard storage? There's no current plans for that but it might be available to residents. Andrew Lightman suggested perhaps some of the weird spaces in the garage could be used for that. Also, will there be casual restaurants? Yes, everything from a walk-up taco window to white tablecloth residents.

4th and M SE: CM Fascett said that DDOT has a plan for this intersection. The crosswalk is treacherous because of the historic turret blocking sightlines. The plan is to create a curb bulbout into 4th St. There is already light timing changes. There will be dedicated left and right turn lanes on 4th Street. This does remove a few parking spaces by USDOT. She moved to send a letter in support of these changes and asking DDOT to consider addition signal timing changes and a right turn on red mechanism. CM Litsky seconded. Passed 7-0-0 (Carroll arrived).

4th and M SW: CM Moffatt moved to send a letter to DDOT asking them to repair a sinkhole in the middle of a crosswalk between the NE and SE sides. DDOT has repaired it poorly twice before: once half-full of asphalt and once with a slippery metal plate. The letter asks for the plate to be removed and the hole repaired. CM Litsky seconded. CM Cloyd suggested adding a photograph. Passed 7-0-0.

Commission Updates and Administrative Matters

- Chair's report: CM Litsky said he is filling out a report for the ANC to send to Zoning about DC United. OP and United are sending him more information. CM Lightman will accompany him to the hearing to assist him. He also attended a 5.5 hour hearing about the Nationals' proposal to

install video signs. Only people from the Nationals and their lobbyist testified in favor. Scenic America, Clear Skies, the Sierra Club, Capitol Hill Restoration Society, a group from Dupont Circle, and others all testified in opposition. Several nearby landowners were in opposition; one was in support because they want to put up their own billboards. Melinda Bolling of DCRA and Sam Zimbabwe at DDOT all testified and gave great weight to the ANC's concerns. Several council members seemed receptive to our concerns. Make sure to tell Charles Allen your thoughts on this.

- Treasurer's report: The quarterly report was submitted.

Community Concerns: none

The commission adjourned at approximately 9:31 p.m.

Minutes prepared by Stacy Cloyd



Near Southeast/Southwest
Advisory Neighborhood Commission 6D

November 14, 2016

1101 Fourth Street, SW
Suite W 130
Washington, DC 20024
202.554.1795
Email: office@anc6d.org
Website: www.anc6d.org

Mayor Muriel Bowser, DOH Director LaQuandra S. Nesbitt, Councilmember Charles Allen,
Acting DGS Director Greer Gillis, DHS Director Laura Zeilinger

VIA E-MAIL: eom@dc.gov, laquandra.nesbitt@dc.gov, callen@dccouncil.us,
greer.gillis@dc.gov, laura.zeilinger@dc.gov

OFFICERS

Chairperson
Andy Litsky

Vice Chairperson
Rachel Reilly Carroll

Secretary
Stacy Cloyd

Treasurer
Meredith Fascett

RE: 850 Delaware Avenue SW Health Center Operator Selection Process

At a regularly scheduled and properly noticed public meeting on November 14, 2016, with a quorum present, a quorum being four Commissioners, Advisory Neighborhood Commission (ANC) 6D voted 6-0-0 to submit the following resolution:

Whereas, the District owns the building at 850 Delaware Ave. SW, and

Whereas, the building is currently occupied by Unity Health Care, which operates a sliding-scale medical clinic serving District residents of all income levels, and

Whereas, the District is currently in the process of developing 850 Delaware Ave. SW into a new health clinic and short-term family housing, and

Whereas, the District has not yet chosen an operator for the new health clinic

Be it resolved that ANC 6D wishes to be involved in the development of a Request for Proposals or any similar solicitation for operators of the 850 Delaware Ave. SW clinic, and strongly encourages the selection criteria for an operator to include:

- Existing connections to residents of the Southwest Waterfront and surrounding neighborhoods
- Continuity of care for existing Unity patients
- Experience providing care to those with public health insurance (Medicare, Medicaid, DC Alliance) and also to those with private insurance and no insurance
- Availability of services for adults and children; laboratory services; mental health and physical health services, and case management.

Sincerely,

Andy Litsky,
Chairman, ANC 6D
Southwest, Navy Yard, and Buzzard Point

COMMISSIONERS

SMD 1 *Marjorie Lightman*
SMD 2 *Stacy Cloyd*
SMD 3 *Rachel Reilly Carroll*
SMD 4 *Andy Litsky*
SMD 5 *Roger Moffatt*
SMD 6 *Rhonda Hamilton*
SMD 7 *Meredith Fascett*



Near Southeast/Southwest

Advisory Neighborhood Commission 6D

1101 Fourth Street, SW
Suite W 130
Washington, DC 20024
202.554.1795
Email: office@anc6d.org
Website: www.anc6d.org

November 15, 2016

Leif Dormsjo, Director
District Department of Transportation
55 M St. SE
Washington, DC 20003

OFFICERS

Chairperson
Andy Litsky

Vice Chairperson
Rachel Reilly Carroll

Secretary
Stacy Cloyd

Treasurer
Meredith Fascett

VIA E-MAIL: leif.dormsjo@dc.gov

RE: Improvements to the Intersection of 4th & M Streets SE

Dear Director Dormsjo:

At a regularly scheduled and properly noticed public meeting on November 14, 2016 with a quorum being present, a quorum being 4 Commissioners, **Advisory Neighborhood Commission (ANC) 6D voted 7-0-0 for the motion to support the proposed curb bulb out and traffic lane changes (as pictured in page 3) for the 4th and M St. SE intersection.**

The ANC appreciates that DDOT has reviewed the configuration of and light timing at this intersection and has proposed improvements in response to the ANC's letter to DDOT dated May 16, 2016 and to the advocacy by the ANC 6D07 Commissioner.

The ANC further appreciates that DDOT has already adjusted the traffic light timing to allow for a leading pedestrian indicator across M St. at the 4th St. SE intersection.

The ANC supports DDOT's proposal to build a curb bulb out into 4th St. SE in order to significantly improve the safety of pedestrians crossing M St.

The ANC supports DDOT's proposal to adjust the traffic lanes on 4th St. SE between M St. and Tingey St. in order to allow for separate right and left turn lanes. The ANC recognizes that this requires the removal of some parking spaces, but views this removal as necessary to ensure sufficient traffic flow out of The Yards portion of the Navy Yard neighborhood.

COMMISSIONERS

SMD 1 *Marjorie Lightman*
SMD 2 *Stacy Cloyd*
SMD 3 *Rachel Reilly Carroll*
SMD 4 *Andy Litsky*
SMD 5 *Roger Moffatt*
SMD 6 *Rhonda Hamilton*
SMD 7 *Meredith Fascett*

The ANC asks that DDOT further study the intersection to determine if right turn on red could be safely allowed for east-bound vehicles on 4th St. at M St. SE simultaneous with the protected left for south-bound vehicles on M St. at 4th St. The ANC makes this request because it recognizes that the residential population in The Yards is expected to grow nearly three-fold upon build-out and that 4th St. SE is a major north/south road for The Yards.

The ANC also asks that DDOT study increasing the timing of the pedestrian signal on M St. from 27 seconds to 30 seconds or more. While the leading pedestrian indicator is a significant improvement, 27 seconds is still insufficient time for many residents, especially seniors and individuals with disabilities to cross M St.'s six lanes, while avoiding east- and west-bound traffic from the northern and southern points of 4th Street.

Should you have any questions, please let me know.

Sincerely,

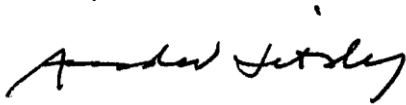
A handwritten signature in black ink, appearing to read "Andy Litsky". The signature is fluid and cursive, with a prominent initial "A".

Andy Litsky
Chairman, ANC 6D
Southwest, Navy Yard & Buzzard Point

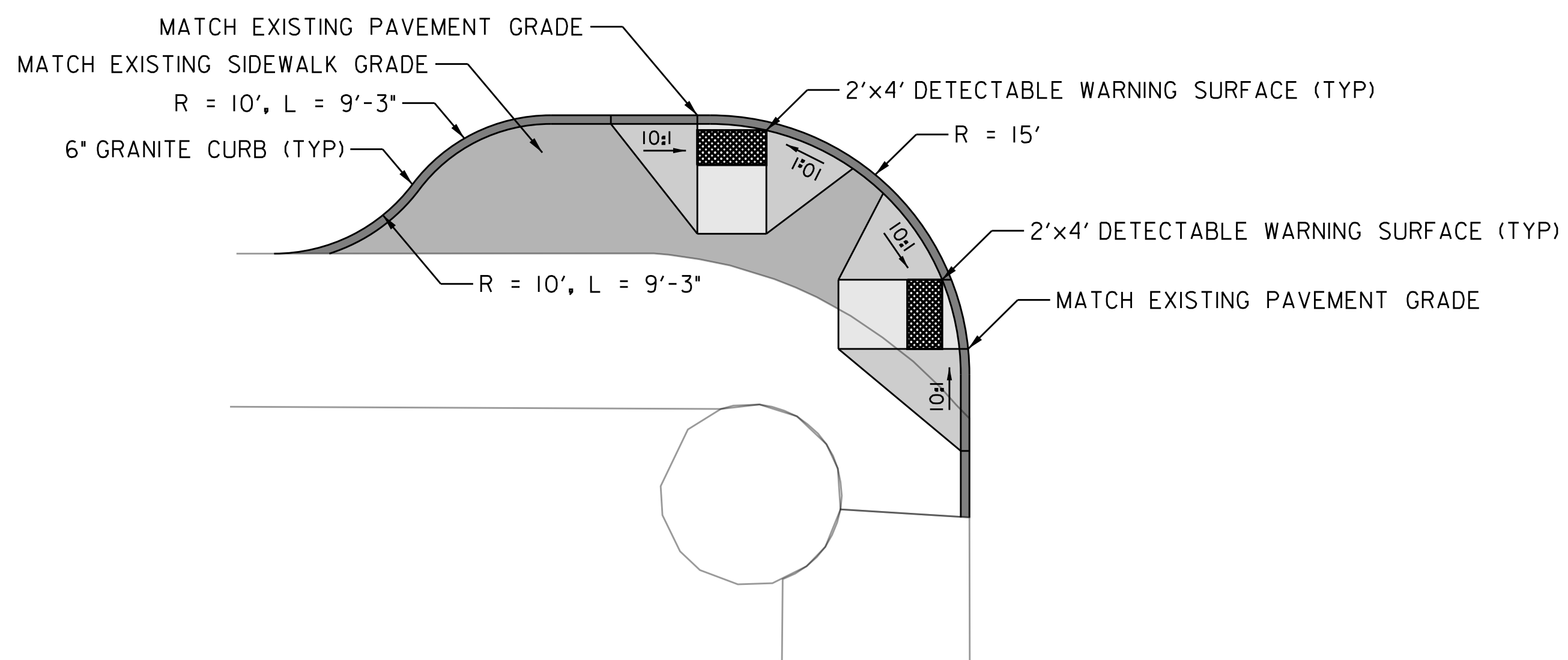
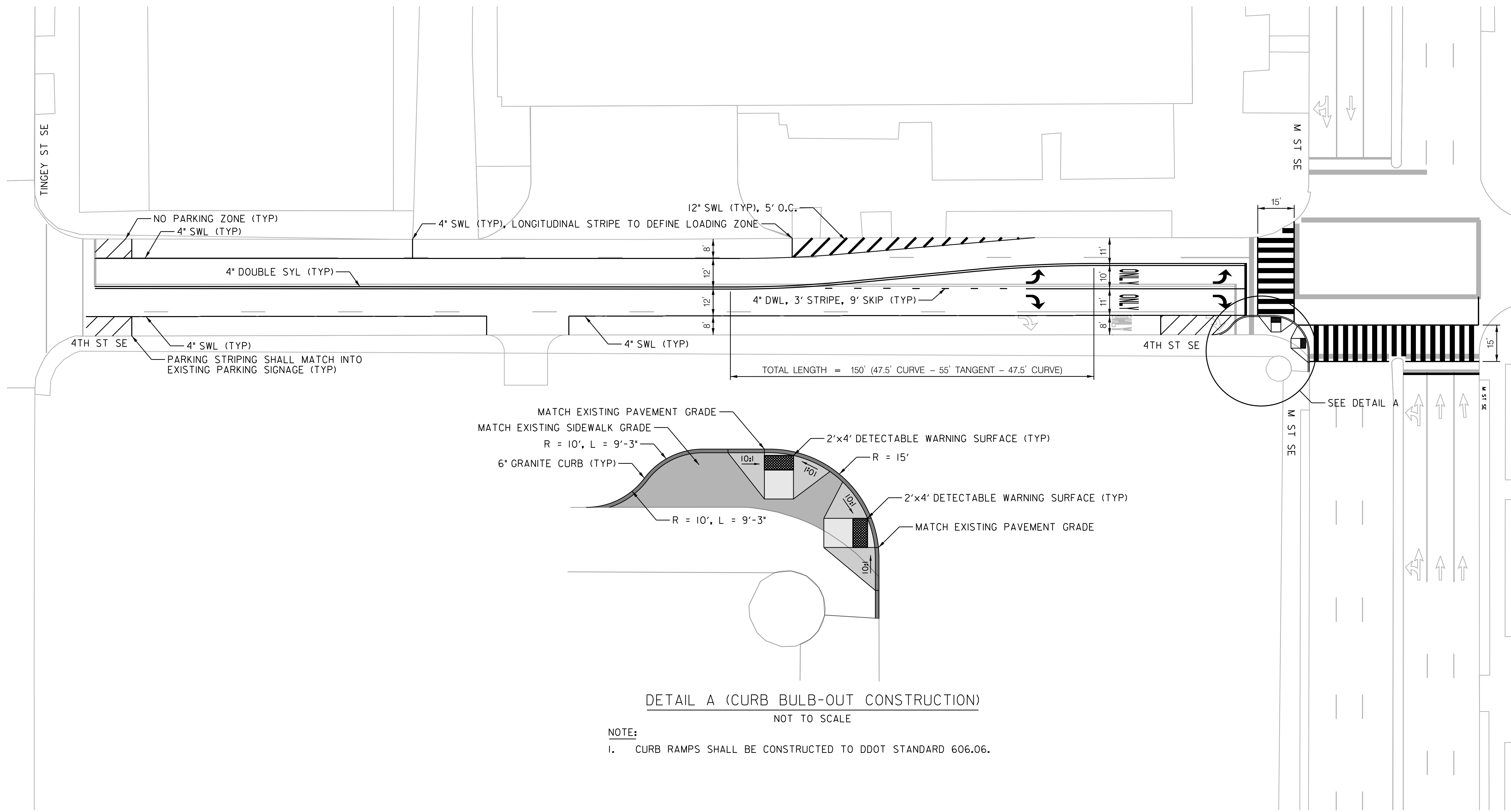

DETAIL A (CURB BULB-OUT CONSTRUCTION)

NOT TO SCALE

NOTE:
 1. CURB RAMPS SHALL BE CONSTRUCTED TO DDOT STANDARD 606.06.

- SIGNING AND PAVEMENT MARKING LEGEND**
- ▲ PROPOSED SIGN ASSEMBLY TO BE INSTALLED
 - EXISTING U-POST SIGN ASSEMBLY
 - ☉ SIGN PANEL(S) MOUNTED ON STREET LIGHT POLE
 - ☉ SIGN PANEL(S) MOUNTED ON TRAFFIC SIGNAL POLE
 - SIGN PANEL TO BE INSTALLED
 - ✕ SIGN PANEL TO BE REMOVED
 - R.E. REMOVE EXISTING MARKINGS

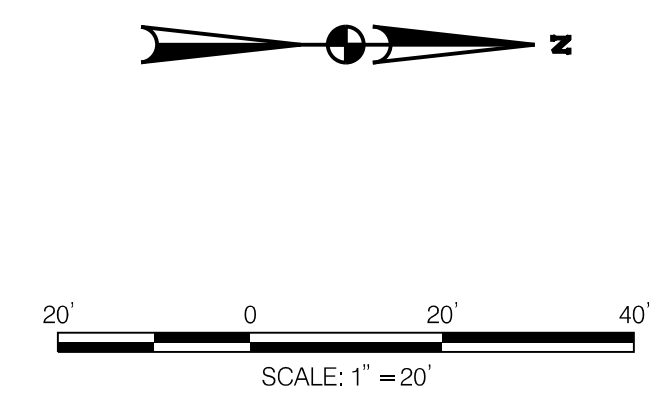

REVISIONS			
2	PRELIMINARY (60%) LAYOUT PLAN	DAG	08-30-2016
1	CONCEPTUAL (30%) LAYOUT PLAN	DAG	05-12-2016

D.C. DEPARTMENT OF TRANSPORTATION
 POLICY, PLANNING, AND SUSTAINABILITY ADMINISTRATION
 BICYCLE AND PEDESTRIAN PROGRAM

LOCATION: 4TH & M ST SE

CURB BULB-OUT LAYOUT & DETAIL SHEET

PROJECT ENG. <u>DLL</u>	DIVISION CHIEF
DESIGNED BY <u>DAG</u>	DATE <u>AUGUST 2016</u>
CHECKED BY <u>MJG</u>	FILE <u>bdr_mjg_se.dgn</u>
DRAWN BY <u>DAG</u>	SHEET <u>1</u> OF <u>1</u>
PROJECT MGR. <u>MJG</u>	



Near Southeast/Southwest

Advisory Neighborhood Commission 6D

1101 Fourth Street, SW
Suite W 130
Washington, DC 20024
202.554.1795
Email: office@anc6d.org
Website: www.anc6d.org

November 14, 2016

District Department of Transportation
Leif Dormsjo, Director DDOT
55 M Street SE
Washington, DC 20003

OFFICERS

Chairperson
Andy Litsky

Vice Chairperson
Rachel Reilly Carroll

Secretary
Stacy Cloyd

Treasurer
Meredith Fascett

VIA E-MAIL: leif.dormsjo@dc.gov

RE: Request to Correct Dangerous Repairs Made by DDOT to a Sinkhole in Pedestrian Crosswalk at Intersection of 4th & M Streets SW

Dear Director Dormsjo,

At a regularly scheduled and properly noticed public meeting on November 14, 2016, with a quorum present, a quorum being four Commissioners, Advisory Neighborhood Commission (ANC) 6D voted 7-0-0 to send this letter requesting correction of repair made to a sinkhole in the Pedestrian crosswalk of M Street SW between the NE & SE corners of the intersection with 4th Street SW by immediately removing the metal plate that creates a major hazard for pedestrians and filling the hole with asphalt to be level with the street. This request was made in the second letter that was written requesting repair of this sinkhole.

In two previous letters regarding to this matter, the ANC shared the fact that a minimum of two requests for repair have been submitted via DDOT's online service request. However, as at least two persons have reported falling, ANC 6D believes that this is an emergency that cannot wait for the 70-day repair period that is suggested online.

In addition, the ANC pointed out the poor installations of metal plates in DC exacerbate an already dangerous situation for pedestrians.

Thank you for your time and consideration in ensuring this request is expedited and for your service to DC residents and visitors.

Sincerely,

Andy Litsky
Chairman, ANC-6D
Southwest, Navy Yard & Buzzard Point

Cc: Ward 6 Councilmember Charles Allen, callen@dccouncil.us
CM Allen's Community Liaison, Naomi Mitchell, nmitchell@dccouncil.us